

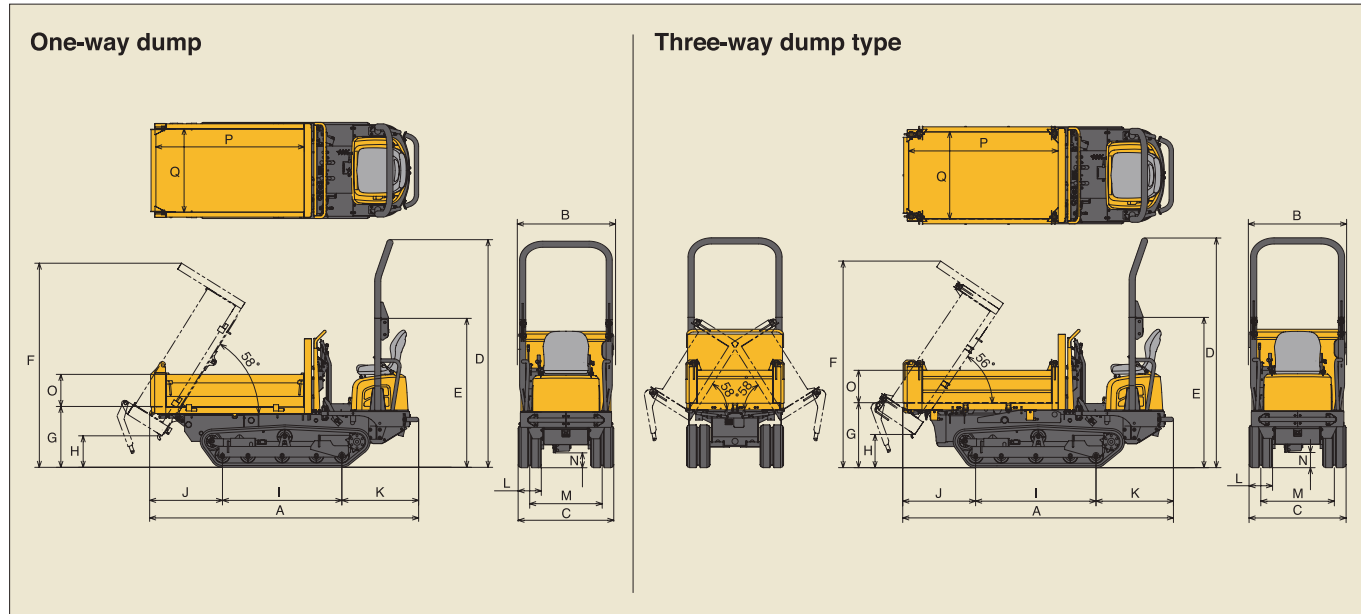

YANMAR

ALL-TERRAIN CARRIER



C12R-B

[Gross] 7.7kW

Dimensions

mm (ft-in)

	A	B	C	D	E	F	G	H	I	J	K	L	M	N	O	P	Q
One-way dump	2650 (8'8")	950 (3'1")	950 (3'1")	2250 (7'5")	1470 (5'9")	6'7" (20'15)	600 (2'0")	310 (1')	1180 (3'10")	710 (2'4")	760 (2'6")	230 (9")	720 (2'4")	150 (6")	320 (1'1")	1470 (4'10")	830 (2'9")
Three-way dump	2650 (8'8")	960 (3'2")	950 (3'1")	2250 (7'5")	1470 (5'9")	6'8" (20'25)	635 (2'1")	325 (1'1")	1180 (3'10")	710 (2'4")	760 (2'6")	230 (9")	720 (2'4")	150 (6")	315 (1')	1470 (4'10")	860 (2'10")

Specifications

Model		C12R-B		
Dump vessel type		One-way	Three-way	
Operating weight	Net, unloaded	kg (lbs)	1010 (2227) / 1100 (2426)	
Engine	Type	Water cooled 2 cyl. Diesel engine		
	Model	2TE67L-FW3		
	Output	kW (hp) / RPM		
Transmission		Hydrostatic & Reduction gear		
Under carriage	Crawler width	mm (ft-in)	230 (9")	
	Min. ground clearance	mm (ft-in)	150 (6")	
	Ground contact pressure	w/o load	kPa (PSI)	18.2 (2.65) / 19.9 (2.88)
		w/ load	kPa (PSI)	39.0 (5.66) / 40.7 (5.89)
Brake	Service brake	Type	Mechanical wet multiple disk	
		Operation	Pedal, mechanical	
	Parking brake	Type	Common with service brake	
		Operation	Lever, pedal lock	
Performance	Max. payload	kg (lbs)	1150 (2540)	
	Dumping angle	Rear	degrees	58 / 56
		Side	degrees	— / 58
	Dump clearance at rear dump	mm (ft-in)	310 (1') / 325 (1'1")	
	Dump body capacity	Struck	m ³ (yd ³)	0.040 (0.52)
		Heaped	m ³ (yd ³)	0.52 (0.68)
Travel speed	Forward	km / h (MPH)	0 - 5.5 (0 - 3.4)	
	Reverse	km / h (MPH)	0 - 5.5 (0 - 3.4)	
Hydraulic system for dump	Pump	Gear		
	Control valve	Single spool		
Fuel tank capacity		L (Gals)	14.5 (4)	



YANMAR CONSTRUCTION EQUIPMENT CO.,LTD.

OVERSEAS SALES DEPT.
MARKETING & SALES DEPT.

1717-1 Kumano, Chikugo, Fukuoka 833-0055, JAPAN
TEL +81-942-53-5465 FAX +81-942-53-5132

yanmar.com

All data subject to change without notice.

ALL-TERRAIN CARRIER C12R-B

Safe Operation

Foldable ROPS Bar and Seat Belt are Standard Equipment

For safe operation on slopes, soft terrain and other potentially hazardous job sites, the distinctive features on the Yanmar C12R-B, reduce risk and improve operator safety.



Versatility

Foldable ROPS Bar

By simply removing a pin the strong and sturdy ROPS bar can be folded, allowing easy access to areas with height restrictions. * Do not fold the ROPS bar while in operation.



The Compact Vehicle with High Work Performance

Overall machine length is only 8'8" by installing the engine under the operators seat. For working in those restricted, narrow access, areas the 3'1" width will get you in and around your jobsite. Being able to tilt the dump bed left, right or out the front, provides an excellent opportunity to function in those confined areas.



Forward / Reverse Lever

The lever switches between forward and reverse traveling. The lever is easy to operate for accurate and safe operation.



Engine Stop Key

Turning the key stops the engine easily and maintains the level of the battery. The layout around the operator's seat is neat and functional.

Durable Machine

Rugged Loading Platform

Floor plate thickness: 0.2inch(4.5mm)
Gate post thickness: 0.1inch(3.2mm)



The rugged structure is another important item for durability on construction sites.

Longer Lasting Undercarriage

The durable undercarriage is the single most important item for a construction use carrier. The use of stronger materials, larger bearings and hardened rolling faces of track rollers all increase the carrier's basic performance.

Easy Maintenance

Fully Open Hood

The engine is housed inside the hood under the operator's seat. The fully open hood allows easy and safe maintenance the engine.



Power

Basic Performance Boosted

Engine performance has been increased. The dependable Yanmar diesel engine provides enough power to handle the maximum payload in rugged conditions.

Clean & Silent

Yanmar's environmentally friendly engine provides powerful output, clean exhaust and improved cold starting performance. The water-cooled two-cylinder diesel engine complies with the EPA's exhaust emission regulation in the U.S. The engine is very quiet and passed the strict European noise regulation laws.