

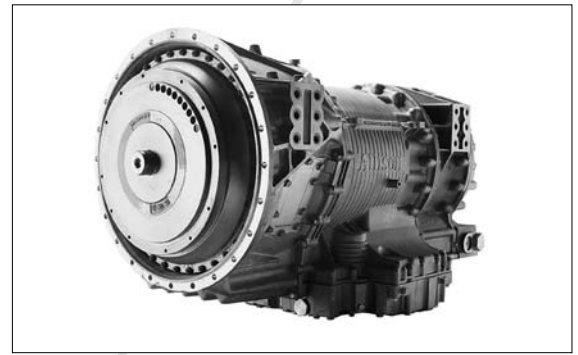

## 4700/4800 Series



### RATINGS

Model <sup>(1)</sup>		Input Torque Gross N•m (lb-ft)	Input Power Gross <sup>(2)</sup> Kw (hp)	Turbine Torque Net <sup>(3)</sup> N•m (lb-ft)	GVW kg (lbs)	GCW kg (lbs)
4700	General, Construction	2400 (1770)	410 (550)	3525 (2600)	n/a	n/a
	Airport Rescue and Fire-Fighting Vehicle	2508 (1850)	447 (600)	3795 (2800)	n/a	n/a
	Heavy Equipment Transport	2508 (1850)	447 (600)	3525 (2600)	n/a	n/a
	Refuse Vehicles	2102 (1550)	373 (500)	3322 (2450)	n/a	n/a
4700 OFS	Oil Field Series	2508 (1850)	447 (600)	3525 (2600)	n/a	n/a
4700 SP	Specialty / Military	2508 (1850)	447 (600)	4067 (3000)	n/a	n/a
4800	Airport Rescue and Fire-Fighting Vehicle	2644 (1950)	507 (680)	3795 (2800)	n/a	n/a
	4800 SP Specialty / Military	2644 (1950)	597 (800)	4067 (3000)	n/a	n/a

(1). Models including vocational designations (ie: ORS, OFS, SP, MH) are for global markets. All other models within this document are targeted for non North American markets only.  
 (2). Gross Power rating as defined by ISO 1585 or SAE J1995. (3). Turbine Torque limit based on iSCAAN standard deductions.

### DRIVETRAIN INTERFACES

Acceptable full-load engine governed speed	1700 – 2300 rpm
Acceptable engine idle speed range (with transmission in Drive)	500 – 800 rpm

### MOUNTING

To Engine	SAE No.1
In Chassis	Rear support available (required for some installations)

### TORQUE CONVERTER

Type	One stage, three element, polyphase. Includes standard integral damper which is operational in lockup.
Model	Stall Torque Ratio
TC-521	2.42
TC-531	2.34
TC-541	1.90
TC-551	1.79
TC-561	1.58

### MECHANICAL RATIOS (Gear ratios do not include torque converter multiplication)

Range	
First	7.63 : 1
Second	3.51 : 1
Third	1.91 : 1
Fourth	1.43 : 1
Fifth	1.00 : 1
Sixth	0.74 : 1
Seventh	0.64 : 1
Reverse	-4.80 : 1

### CONTROL SYSTEM

<b>Description</b>	Allison 4th Generation Electronic Controls with closed loop adaptive shifts
<b>Shift Sequences</b>	[C = Converter mode (lockup clutch disengaged); L = Lockup mode (lockup clutch engaged)] Option 1: 1C-[1L]-2C-2L-3L-4L-5L Option 2: 1C-[1L]-2C-2L-3L-4L-5L-6L Option 3: 1C-[1L]-2C-2L-3L-4L-5L-6L-7L TCM must be calibrated for "1L" option. Second-gear-start calibrations are not available for all vehicle applications.
<b>Driver-to-Transmission Interface</b>	Cab-mounted shift selector, pushbutton or lever with two-digit display (range selected and range attained)
<b>Communication Protocol - Engine/Vehicle Systems Interface</b>	SAE J1939, SAE J1587, ISO 9141, IESCAN

International Series 4700/4800

**PHYSICAL DESCRIPTION**

	Length*	Dry Weight	Depth below transmission centerline
Basic Model	1049 mm (41.3 in)	493 kg (1087 lbs)	375 mm (14.8 in)
With PTO Drive Provision	1122 mm (44.2 in)	521 kg (1145 lbs)	375 mm (14.8 in)
With Retarder	1049 mm (41.3 in)	527 kg (1162 lbs)	375 mm (14.8 in)
With PTO Drive Provision and Retarder	1122 mm (44.2 in)	555 kg (1224 lbs)	375 mm (14.8 in)

\*Approximate length from engine housing to output flange (depending on output flange type)

**ENGINE-DRIVEN POWER TAKE-OFF PROVISION**

PTO drive	Engine-driven helical gear	
PTO mounting pads	Ten-bolt, 1 o'clock and 8 o'clock positions (as viewed from rear)	
PTO drive gear ratio	1 o'clock position	1.00 x engine speed
	8 o'clock position	1.00 x engine speed
PTO drive gear rating (continuous operation)	Using one PTO:	930 N•m (685 lb-ft)
	Total using two PTO's:	1595 N•m (1175 lb-ft)
PTO Drive Gear	97 tooth	

**OUTPUT RETARDER PROVISION (OPTION)**

Type	Integral, hydraulic	
	Torque	Power
Low	1763 N•m (1300 lb-ft)	373 kW (500 hp)
Medium	2170 N•m (1600 lb-ft)	447 kW (600 hp)
High	2710 N•m (2000 lb-ft)	447 kW (600 hp)

**OIL SYSTEM**

Allison approved fluids: TES 295 and TES 389	
Capacity excluding external circuits	
With PTO	51 litres (54 quarts)
Without PTO	48 litres (51 quarts)
Main circuit oil filter	Replaceable element, integral
Cooler circuit oil filter	Replaceable element, integral
Electronic oil level sensor (OLS)	Standard

**SPEEDOMETER PROVISION**

Description	Non-zero-crossing square wave
	8, 16 or 40 pulses per revolution of transmission output shaft
Location	Electronic output from TCM

**TACHOGRAPH PROVISION**

Tone wheel	4 or 6-tooth
Mounting	M18 x 1.5 metric thread
Location	Transmission rear cover or retarder housing

**4700/4800 Series**  
With Retarder, PTO and Deep oil sump

