

Rigid Haul Truck

MAX. GROSS VEHICLE	122,300 lbs (55,475 kg)
NET ENGINE POWER	369 hp (276 kW)
MAX PAYLOAD	35 Tons (31.8 t)
HEAPED CAPACITY	25.0 Yd ³ (19.4 m ³)

Specifications

Engine	
Make / model	Cummins QSM11-C400E
Type	4 cycle turbocharged, charge-aircooled
Gross power @ 2,100 rpm (SAE J 1995)	400 hp (298 kW)
Net power @ 2,100 rpm (SAE J 1349)	369 hp (276 kW)
Engine emission meets Tier III USA EPA/CARB MOH 40 CFR 89 and EU non-road mobile machinery directive. Stage 3.	
Maximum torque @ 1,400 rpm	1,400 lbf ft (1,899 Nm)
Cylinders/configuration	6 in-line
Bore x stroke	4.9 x 5.8 in (125 x 147 mm)
Displacement	661 in ³ (10.8 liters)
24 volt negative ground electrical system. Two 12 volt 165 Ah batteries with master disconnect switch. 7.7 kW electric starter. Neutral start. 70A alternator.	

Transmission						
Allison 4500 RDS. Remote mounted in the frame with integral torque converter, hydraulic retarder and planetary gearing. Five speeds forward, one reverse. Automatic shifting within ranges 2 to 5. Downshift and reverse inhibitors. Automatic lock-up in all speed ranges. Speeds with standard differential and tires:						
	Forward					Reverse
Gear	1	2	3	4	5	R 9.9
Ratio	5.20	3.20	2.00	1.40	1.00	2.14
mph	5.9	12.6	18.2	27.8	37.0	5.3
km/h	9.5	20.3	29.3	44.8	59.0	8.5

Frame
Full box section frame rails, integral front bumper, closed-loop cross member and torque tubes of 42,000 psi (290 MPa) yield strength steel. Cross member connections are 95,000 psi (655 MPa) steel castings.

RIGID HAUL TRUCK
TR35

Specifications

Axles		
Terex heavy duty axle with full floating axle shafts, single reduction spiral bevel gear differential, and planetary reduction at each wheel.		
Ratios:	Standard	Optional
Differential	2.50:1	3.13:1
Planetary	4.59:1	4.59:1
Total reduction	11.48:1	14.37:1

Tires and Wheels		
Standard: front and rear	18.00-25 (32 PR) E-3	rim width 13"
Consult tire manufacturers for optimum tire selection and correct ton-mile/h (t-km/h) capacity for application. Tires subject to availability.		

Suspension	
Front: Terex manufactured king pin strut-type independent front wheel suspension by self-contained, variable rate, nitrogen/oil cylinders.	
Rear: Terex variable rate nitrogen/oil cylinders with A-frame linkage and lateral stabilizer bar.	
Maximum strut stroke:	
Front	9 in (225 mm)
Rear	6.3 in (160 mm)
Maximum rear axle oscillation	± 8.0°

Brakes	
SERVICE – Dual shoe, internal expanding, mechanically actuated by air pressure. Independent front and rear systems actuated by single treadle valve with auxiliary manual control. Operator controlled wet/dry road valve reduces front brake pressure 50% for improved control in slippery conditions.	
Front linings: diameter x width	20 x 6 in (508 x 152 mm)
Lining area - front axle	536 in ² (3,459 cm ²)
Rear linings: diameter x width	20 x 7.5 in (508 x 190 mm)
Lining area - rear axle	670 in ² (4,323 cm ²)
Total lining area	1,206 in ² (7,782 cm ²)
Air compressor capacity	15 ft ³ /min (425 Lpm)
SECONDARY – Warning light in cab indicates when air pressure drops below 80 psi (5.5 bar). Front and rear brakes automatically actuate if system air pressure falls to 45 psi (3.1 bar).	
Total Brake Air Reservoir Capacity	4,950 in ³ (81 L)
PARKING – Service brakes act as parking brakes when applied by manual control valve on the instrument panel.	
RETARDATION – Non-wearing hydrodynamic retarder integral with transmission. 430 hp (320 kW) continuous.	

Steering	
Independent hydrostatic steering with closed-center steering valve, accumulator and pressure compensating piston pump. Accumulator provides uniform steering regardless of engine speed. In the event of loss of engine power it provides steering of approximately two lock-to-lock turns. A low pressure warning light indicates should the system pressure fall below 1,200 psi (83 bar). Steering conforms to ISO 5010, (SAE J 53).	
Maximum tire steering angle	42°

Hoist	
Two body hoists mounted inside the frame rails. Hoists are two stage with power down in the second stage. The body hydraulic system is independent of the steering hydraulic system.	
System Relief Pressure	2,000 psi (138 bar)
Body Hydraulic Pump Flow Rate @ 2,100 rpm engine	55.5 gpm (210 Lpm)
Body raise time	14.0 sec
Body lower time	9.5 sec

Body		
Longitudinal 'V' type floor with integral transverse box-section stiffeners. The body is exhaust heated and rests on resilient impact absorption pads.		
Body wear surfaces are high hardness (360-440BHN) abrasion resistant steel of yield strength 145,000 psi (1 000 MPa).		
ROPS Cabguard (SAE J 1040) ISO 3471.		
Thickness:	Floor	0.63 in (16 mm)
	Side	0.31 in (8 mm)
	Front, lower	0.39 in (10 mm)
Volumes:	Struck (SAE Std)	20.0 yd ³ (15.3 m ³)
	Heaped 2:1 (SAE Std)	25.0 yd ³ (19.4 m ³)

Service Capacities	
Engine crankcase and filters	9.0 gal (34.0 L)
Transmission and filters	7.0 gal (26.5 L)
Cooling system	24.8 gal (94.0 L)
Fuel tank	98.0 gal (371.0 L)
Steering hydraulic tank	8.0 gal (30.0 L)
Steering hydraulic system (total)	12.4 gal (47.0 L)
Body hydraulic tank	22.0 gal (83.0 L)
Body hydraulic system (total)	32.0 gal (121.0 L)
Planetaries (total)	8.0 gal (30.0 L)
Differential	15.0 gal (57.0 L)
Front ride strut (each)	3.7 gal (14.0 L)
Rear ride strut (each)	2.1 gal (8.0 L)
Power take off	0.2 gal (0.6 L)

Standard Equipment

CAB	Coolant temp
Acoustic lining	Direction indicators
Air conditioner R 134A 18,500 BTU/hr (5.4 kW)	Engine oil pressure
Armrest, operators door	Headlamps, main beam
Door locks	Parking brake on
Floor mat	Retarder on
FOPS protection (ISO 3449/SAE J 231)	Steering filter restriction
Heater and defroster (10.3 kW - 35,000 BTU/hr)	Transmission filter restriction
Interior light/courtesy light	Transmission oil temperature
Mug holder	Warning light test
Radio/cassette player	GENERAL
ROPS protection (body cabguard) (ISO 3471/SAE J1040)	Accumulator steering
Air suspension seat with high back, headrest and 4-point harness	Air cleaners (2), two stage
Seat, passenger	Air system dryer
Seat belts SAE J386	Automatic transmission
Steering column, adjustable	Body down signal
Sun visor, full cab width	Body heating, exhaust
Tinted glass	Body hoist, servo actuated
Utility compartment	Brake dirt shields
Window, electric - operators door	Coolant filter
Windshield wipers - 2 speed and washers	Diagnostic pressure test points
CONTROLS	Downshift inhibitor
Battery isolator	Dual brake system
Auto transmission shift	Electric start
Gauges	Engine management system
Air pressure	Engine pan guard
Converter temp	Exhaust muffler (body up)
Engine coolant temp	Fuel sight gauge
Engine oil pressure	Headlights - quartz halogen (4)
Fuel	Mud flaps
Speedometer/odometer	Nitrogen inflated tires
Tach/hourmeter	Operator arm guard
Transmission oil pressure	Parking brake (all wheels)
INDICATOR LIGHTS & ALARM	Rear view mirrors - 4
Air pressure	Retarder (hydraulic)
Steering pressure	Retarder light - amber, rear
Transmission "do not shift"	Reverse alarm
INDICATOR LIGHTS ONLY	Reversing light- quartz halogen
Air cleaner restriction	Rock ejectors
Alternator not charging	Secondary brake system (all wheels)
Body up	Security kit
Converter drive	Separate steering and body hoist hydraulic systems
Coolant level	Side, tail, stop, direction indicators and hazard warning lights
	Tires, 18.00-25 (32PR) E3
	Tow points, front and rear
	Transmission guard
	Warning horn

Optional Equipment

GENERAL	Fan clutch
Alternator, 100 amp	Fast fuel adapter
Automatic lubrication	Fire extinguisher
Beacon, flashing amber	Fire suppression system
Body, heavy duty	Flashing strobe reverse light
Body wear plates (floor, end, side and front protection)	Oil drain kit, engine and transmission sumps
Cold start kit	On-board weighing system
Differential, no spin	Spillguard extension, folding
Differential 3.13:1	Tachograph
Engine pre-lube starter	Television monitor, rear view
Exhaust muffler, full-time	Tool kit, hand

Weights

Chassis, with hoists	39,070 lbs (17,725 kg)
Body, standard	13,230 lbs (6,000 kg)
Net Weight	52,300 lbs (23,725 kg)
Payload, maximum	70,000 lbs (31,750 kg)
Maximum Gross Weight*	122,300 lbs (55,475 kg)

FOR UNIT EQUIPPED WITH OPTIONAL HEAVY DUTY ROCK BODY:

Chassis, with hoists	39,070 lbs (17,725 kg)
Body, heavy duty, rock	15,880 lbs (7,200 kg)
Net weight	54,950 lbs (24,925 kg)
Payload, maximum	30,550 lbs (67,350 kg)
Maximum gross weight*	55,475 lbs (122,300 kg)

*Maximum permissible gross vehicle weight with options, attachments, full fuel tank

WEIGHT DISTRIBUTION	Front Axle	Rear Axle
Empty	48%	52%
Loaded	33%	67%

Rigid Haul Truck TR35

Performance Data (Graphs Based On 0% Rolling Resistance)

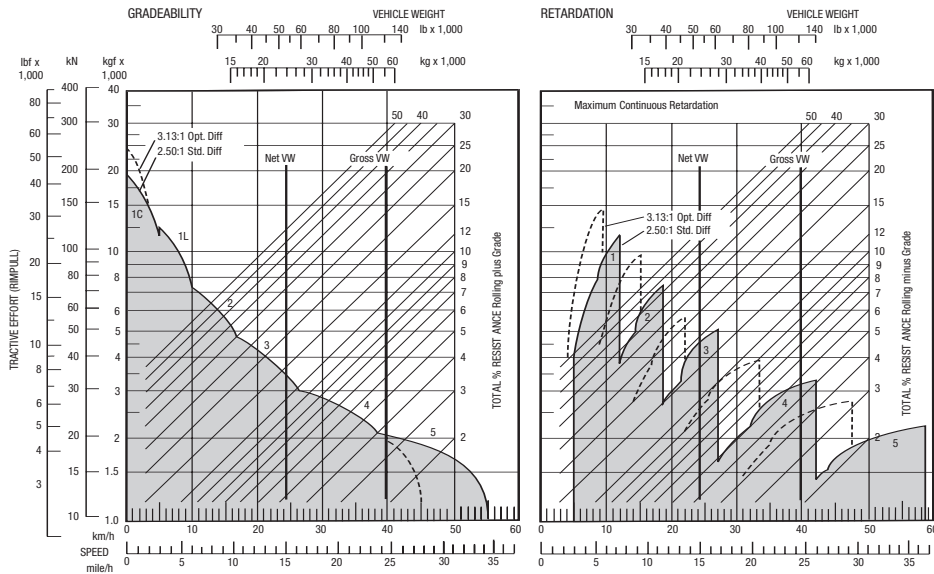

Dimensions

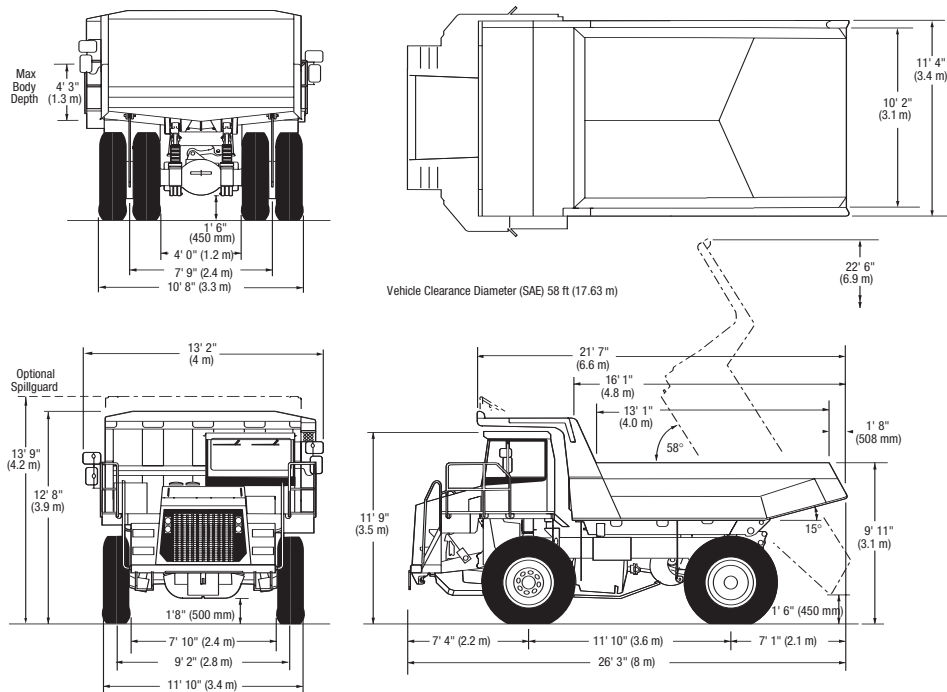

For more information, product demonstration, or details on purchase, lease and rental plans, please contact your local Terex Distributor.

Terex Construction Americas

8800 Rostin Road
Southaven, MS 38671
USA

TEL 662-393-1800
SALES 866-837-3923
PARTS & TECH SUPPORT 888-201-6008
FAX 662-393-1700
EMAIL sales@terexca.com
WEB terexca.com

Effective date: August 15, 2006. For further information, please contact your local distributor or the Terex sales office listed. Product specifications are subject to change without notice or obligation. The photographs and drawings in this brochure are for illustrative purposes only. Refer to the appropriate Operator's Manual for instructions on the proper use of this equipment. Failure to follow the appropriate Operator's Manual when using our equipment or to otherwise act irresponsibly may result in serious injury or death. Prices and specifications subject to change without notice. The only warranty applicable is the standard written warranty applicable to the particular product and sale. Terex makes no other warranty, expressed or implied. Products and services listed may be trademarks, service marks or trade-names of Terex Corporation and/or its subsidiaries in the USA and other countries and all rights are reserved. "Terex" is a Registered Trademark of Terex Corporation in the USA and many other countries. Copyright ©2007 Terex Corporation